



# Fishing

## Merit Badge Workbook

This workbook can help you but you still need to read the merit badge pamphlet (book). No one can add or subtract from the Boy Scout Requirements #33215. Merit Badge Workbooks and much more are below: [Online Resources](#).

Workbook developer: [craig@craiglincoln.com](mailto:craig@craiglincoln.com). Requirements revised: 2002, Workbook updated: March 2008.

Scout's Name: \_\_\_\_\_ Unit: \_\_\_\_\_

Counselor's Name: \_\_\_\_\_ Counselor's Ph #: \_\_\_\_\_

1) Explain to your counselor the injuries that could occur while fishing and the proper treatment, including cuts, scratches, \_\_\_\_\_

puncture wounds, \_\_\_\_\_

insect bites, \_\_\_\_\_

hypothermia, \_\_\_\_\_

dehydration, \_\_\_\_\_

and heat reactions. \_\_\_\_\_

Explain how to remove a hook that has lodged in your arm. \_\_\_\_\_

Name and explain five safety practices you should always follow while fishing.

\_\_\_\_\_  
\_\_\_\_\_  
\_\_\_\_\_  
\_\_\_\_\_

2) Learn and explain the differences between two types of fishing outfits. Type 1: \_\_\_\_\_

Type 2: \_\_\_\_\_ Differences: \_\_\_\_\_

Point out and identify the parts of several types of rods and reels. Explain how and when each would be used. Review with your counselor how to care for this equipment.

Sample Saltwater Reel



How used: \_\_\_\_\_

When used: \_\_\_\_\_

Care: \_\_\_\_\_

Sample Bait-casting Reel

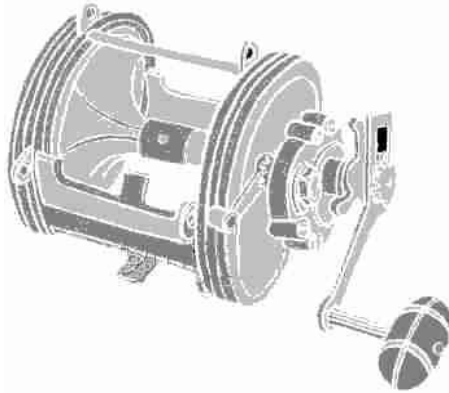

\_\_\_\_\_

\_\_\_\_\_

\_\_\_\_\_

Sample Spinning Rod & Reel

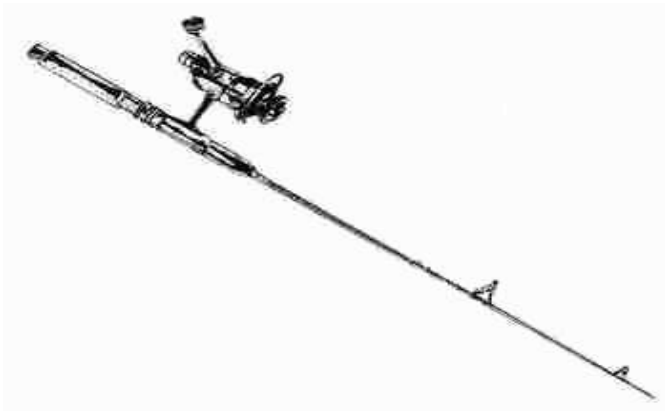

How used: \_\_\_\_\_

When used: \_\_\_\_\_

Care: \_\_\_\_\_

Sample Fly Fishing Rod & Reel



\_\_\_\_\_

\_\_\_\_\_

\_\_\_\_\_

Sample Fishing Rods



Care: \_\_\_\_\_

3) Demonstrate the proper use of two different types of fishing equipment. \_\_\_\_\_

\_\_\_\_\_

4) *Demonstrate* how to tie the following knots: clinch, palomar, turle, blood loop (barrel knot), and the surgeon's loop. Explain how each knot is used and when to use it.

clinch, \_\_\_\_\_

palomar, \_\_\_\_\_

turle, \_\_\_\_\_

blood loop (barrel knot), \_\_\_\_\_

and the surgeon's loop. \_\_\_\_\_

5) Name and Identify five Artificial Lures and explain how to fish with them:

\_\_\_\_\_

\_\_\_\_\_

\_\_\_\_\_

\_\_\_\_\_

\_\_\_\_\_

Name and Identify five Natural Baits and explain how to fish with them:

\_\_\_\_\_

\_\_\_\_\_

\_\_\_\_\_

\_\_\_\_\_

\_\_\_\_\_

Explain why baitfish are not to be released. \_\_\_\_\_

\_\_\_\_\_

\_\_\_\_\_

6) Explain the importance of practicing Leave No Trace and how it positively affects fishing resources. \_\_\_\_\_

\_\_\_\_\_

\_\_\_\_\_

\_\_\_\_\_

\_\_\_\_\_

\_\_\_\_\_

7) Give the regulations affecting game fishing where you live. Explain why they were adopted and what you accomplish by following these regulations.

\_\_\_\_\_

\_\_\_\_\_

\_\_\_\_\_

\_\_\_\_\_

---



---



---



---

8) Explain what good outdoor sportsmanlike behavior is and how it relates to fishermen. \_\_\_\_\_

---



---



---

Tell how the Outdoor Code of the Boy Scouts of America relates to a fishing sports enthusiast, including the aspects of littering, trespassing, courteous behavior, and obeying fishing regulations. \_\_\_\_\_

---



---



---

9) Catch two different kinds of fish and identify them. \_\_\_\_\_

Release at least one of them unharmed. Clean and cook another fish. \_\_\_\_\_

---

**Online Resources** (Use any Internet resource with caution and only with your parent's or guardian's permission.)

**Merit Badge Workbooks:** [usscouts.org](http://usscouts.org) -or- [meritbadge.org](http://meritbadge.org)

► **Merit Badge Books:** [www.scoutstuff.org](http://www.scoutstuff.org)

Boy Scouts of America: <http://www.scouting.org/>

► [Requirements](#)

► [Intro to Merit Badges](#)

[Guide to Safe Scouting](#)

[Leave No Trace](#)

[Outdoor Code](#)

[Wilderness Use Policy](#)

[Youth Protection Training](#)

[ExpertVillage First Aid Videos](#)

📺 [Make a First Aid Kit](#)

📺 [Basics](#)

📺 [Basics2](#)

📺 [CPR Basics](#)

📺 [Venomous Snake Bite](#)

[ExpertVillage Fishing Videos](#)

► [Basics for Kids](#)

► [Advanced Fishing](#)

► [How to Fillet a Fish](#)

American Fisheries Society: <http://www.fisheries.org>

American Zoo and Aquarium Association: <http://www.aza.org>

American Sportfishing Assn.: <http://www.asafishing.org>

Future Fisherman Foundation: <http://www.futurefisherman.org>

Izaak Walton League of America: <http://www.iwla.org>

National Oceanic and Atmospheric Administration Fisheries: <http://www.nmfs.noaa.gov>

Nat. Fish and Wildlife Foundation: <http://www.nfwf.org>

National Park Service: <http://nps.gov>

Trout Unlimited: <http://www.tu.org>

U.S. Fish and Wildlife Service: <http://www.fws.gov>